

GENDRON[™]
by graham-field

PL800 / PL800S MAXICARE BARIATRIC PATIENT LIFT

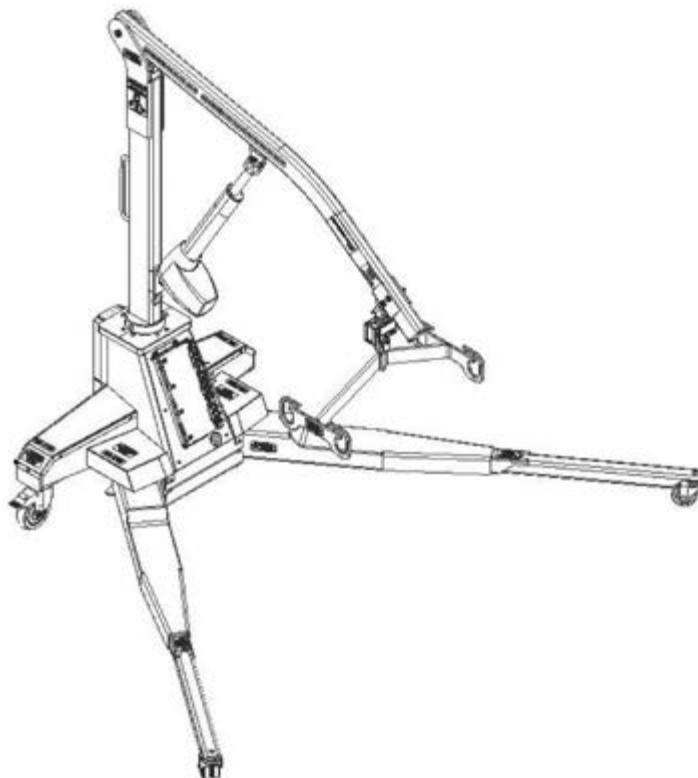

USER MANUAL

GD_PL800-INS-LAB-RevA20

Read this manual before operating your Patient Lift.

Save this manual for future use.

CONTENTS

1	INTRODUCTION.....	3
2	SAFETY PRECAUTIONS.....	4
	WARNINGS.....	4
	ELECTROMAGNETIC COMPATIBILITY (EMC).....	5
3	FEATURES.....	6
	LIFT COMPONENTS.....	6
4	HANDLING PROCEDURES.....	7
	SHIPPING AND TRANSPORTATION INSTRUCTIONS.....	7
5	SETUP.....	8
	CHARGING THE BATTERY.....	8
	LIFT PREPARATION.....	8
6	OPERATION.....	10
	LIFT OPERATION – GENERAL WARNINGS.....	10
	USING THE HANDSET.....	11
	LOCKING THE CASTERS.....	11
	POSITIONING THE LEGS.....	12
	LIFTING THE PATIENT.....	13
	EMERGENCY POWER-OFF BUTTON AND LOWERING COLLAR.....	17
	PL800S ONLY: OPERATING THE SCALE AND WEIGHING THE PATIENT.....	18
7	CARE AND MAINTENANCE.....	20
	BEFORE EACH USE.....	20
	AT LEAST ONCE A MONTH.....	20
	LUBRICATION.....	20
	CLEANING.....	21
	CARE OF SLINGS.....	21
	MAINTENANCE SCHEDULE.....	21
8	TROUBLESHOOTING.....	22
	TROUBLESHOOTING GUIDE.....	22
	BATTERY TECHNICAL GUIDE.....	22
9	SPECIFICATIONS.....	24
10	LIMITED WARRANTY.....	25
11	INDEX.....	27

1 INTRODUCTION

Congratulations on your purchase of the Gendron PL800 Patient Lift / PL800 Patient Lift with Scale. The following pages will provide you with important safety and operating instructions on the use of patient lifts, slings, and accessories, as well as maintenance and warranty information. Read this manual carefully before operating your patient lift and refer to it as often as needed. Consult your authorized distributor and / or healthcare professional with any questions or concerns regarding safe and effective techniques for operating your patient lift.

DO NOT attempt any transfer without prior approval of the patient's healthcare provider. With their assistance, select the sling that best serves the needs, abilities, comfort and safety of the person being lifted. It is important that you use correct slings adapted to the body shape and weight and ability of the patient and the specific type of transfer needed.

Upon receipt of the patient lift, and prior to each use, inspect it closely to ensure that nothing is damaged, there are no loose or broken parts, that all patient lift parts are in the proper place, etc. Immediately replace any worn or broken components. Your patient lift should receive maintenance on a regular schedule and should be inspected daily for proper operation. Contact GF Tech Support at 1.770.368.4700 with any maintenance concerns.

Before lifting anyone, thoroughly read the instructions in this manual. Ideally, observe a team of trained experts performing the lifting procedures. The operator should then practice the entire lifting procedure several times with proper supervision and with a capable individual acting as patient. It is extremely important to know how a patient will feel in the patient lift. We suggest that the operator try all the various lifting slings and equipment until the operator is confident with how the patient lift operates. The lifting procedures should be explained to the patient before the actual lifting. Remember that safety requires the constant attention of the lift occupant and the operator. Use extreme care and common sense when operating a patient lift.

This guide covers the use of the Gendron PL800 Patient Lift. Keep in mind that the basic safety procedures included in this manual are to be used as a guide only. You may find it necessary to develop your own unique methods for safely utilizing the patient lift. Again, consult your healthcare professionals for their recommendations and never hesitate to ask for their assistance.

Info: Before attempting to assemble the patient lift, refer to the ASSEMBLY INSTRUCTIONS section in this manual. Contact GF Tech Support at 1.770.368.4700 or your GF authorized distributor if additional assistance is needed.

Info: In this manual, the person being lifted is referred to as the "patient" or "occupant" and the person operating the patient lift is called the "operator" or "attendant".

Intended use

The Gendron PL800 Patient Lift is intended to aid in the transfer of an individual who is unable to independently transfer between bed, chair, bathtub, wheelchair, and / or commode.

⚠ WARNING: The Gendron PL800 Patient Lift is designed for transfer only (to and from bed, chair, bathtub, toilet, wheelchair, commode etc.). This Patient Lift is not intended to be used for transporting or moving a patient from one location to another.

2 SAFETY PRECAUTIONS

IMPORTANT: Before using patient lift, read and adhere to the following safety precautions and warnings. Failure to do so could result in serious personal injury or damage to your patient lift.

Always consult your healthcare professional to determine safe methods most suitable for your individual abilities. Protect yourself, your attendant and patient lift by having it serviced regularly. If you experience any malfunction, contact GF Tech Support at 1.770.368.4700 or your GF authorized distributor immediately, as a hazardous condition could result, causing personal injury or damage to your patient lift.

Periodic inspection, adjustment and replacement of worn parts are necessary to provide years of excellent service. Refer to *CARE AND MAINTENANCE* section of this manual.

Maintenance **MUST** be performed by qualified personnel **ONLY**.

Significance of safety statements

Note the following special statements, used throughout this manual, and their significance:

- ⚠ WARNING:** Indicates a potential hazard situation or unsafe practice that, if not avoided, could result in death or serious personal injury.
- ⚠ CAUTION:** Indicates a potential hazard situation or unsafe practice that, if not avoided, could result in minor or moderate personal injury.
- ▲ NOTICE:** Indicates a potential hazard situation or unsafe practice that, if not avoided, could result in product or property damage.

Info: Provides application recommendations or other useful information to ensure that you get the most from your product.

WARNINGS

- ⚠ WARNING:** Important! Read and understand these instructions before assembling or using the Gendron PL800 Patient Lift. If you do not understand any part of these warnings, cautions or instructions, contact a healthcare professional for direction in the use of this product. If the Gendron PL800 Patient Lift is not properly assembled, personal injury and damage to the PL800 could result.
- ⚠ WARNING:** If components are damaged or missing, contact your GF authorized distributor immediately. **DO NOT** use substitute parts. Use only Gendron replacement parts. The use of non-Gendron replacement parts could cause personal injury, property damage, and void the warranty.
- ⚠ WARNING:** Unauthorized modification of your patient lift could cause personal injury, property damage, and void the warranty.
- ⚠ WARNING:** The Gendron PL800 Patient Lift maximum weight capacity is 800 lb (362 kg), **EVENLY DISTRIBUTED**. **DO NOT** exceed the maximum weight capacity.
- ⚠ WARNING:** GF Health Products, Inc. assumes no responsibility for any damage or injury caused by improper assembly or use of this product.
- ⚠ WARNING:** Check all parts for shipping damage before using. In case of damage, **DO NOT USE** the equipment. Contact the carrier or your GF authorized distributor for further instructions.

- ⚠ WARNING: Patient lift may tip over if used incorrectly. Read and adhere to the operating instructions prior to lifting anyone.**
- ⚠ WARNING: GF Health Products, Inc. strongly recommends that two caregivers take part in the lifting process.**
- ⚠ WARNING: When transferring a patient, always keep the patient centered over the base.**
- ⚠ WARNING: Ensure that lifting sling loops are correctly attached to the hooks to prevent the patient from sliding or falling out of the sling, which could result in personal injury. Never use the patient lift to lift or transfer anything other than a person.**
- ⚠ WARNING: The rear casters must be locked to prevent movement while the patient is lifted.**
- ⚠ WARNING: Do not attempt to maneuver the lift by pushing on the mast, boom, actuator, or patient. Always maneuver the lift with the handle.**
- ⚠ WARNING: The patient lift legs must be in the maximum open and fully extended position in order for any lift or rotation functions to operate..**
- ⚠ WARNING: To facilitate movement, close patient lift legs before moving the lift.**
- ⚠ WARNING: Replace any worn or broken parts immediately! Torn, cut, frayed, or broken slings can fail, resulting in serious personal injury. Use only slings that are in good condition.**
- ⚠ WARNING: Use extreme care, caution, and common sense when utilizing a patient lift. Special attention must be given to patients who are disoriented and cannot cooperate while being lifted, such as comatose, agitated, spastic, or mentally confused persons. Consult their healthcare professional for assistance in lifting these types of patients.**
- ⚠ WARNING: Cancer and Reproductive Harm - www.p65warnings.ca.gov.**
- ⚠ WARNING: GF Health Products, Inc. specifically disclaims responsibility for any bodily injury or property damage which may occur during any use which does not comply with federal, state or local laws or ordinances.**

ELECTROMAGNETIC COMPATIBILITY (EMC)

Medical electrical equipment needs special precautions regarding electromagnetic compatibility (EMC) and needs to be installed and put into service according to the EMC information provided.

1. Portable and mobile Radio Frequency (RF) communications equipment can affect medical electrical equipment. This product is intended for use in the electromagnetic environments specified.
2. The end user of this product should assure it is used in such an environment.
 - a. Portable and mobile RF Communications equipment (cell phones) should not be used at close distances
 - b. Power frequency magnetic fields should be at levels characteristic of a typical location in a typical commercial or hospital environment.

3 FEATURES

LIFT COMPONENTS

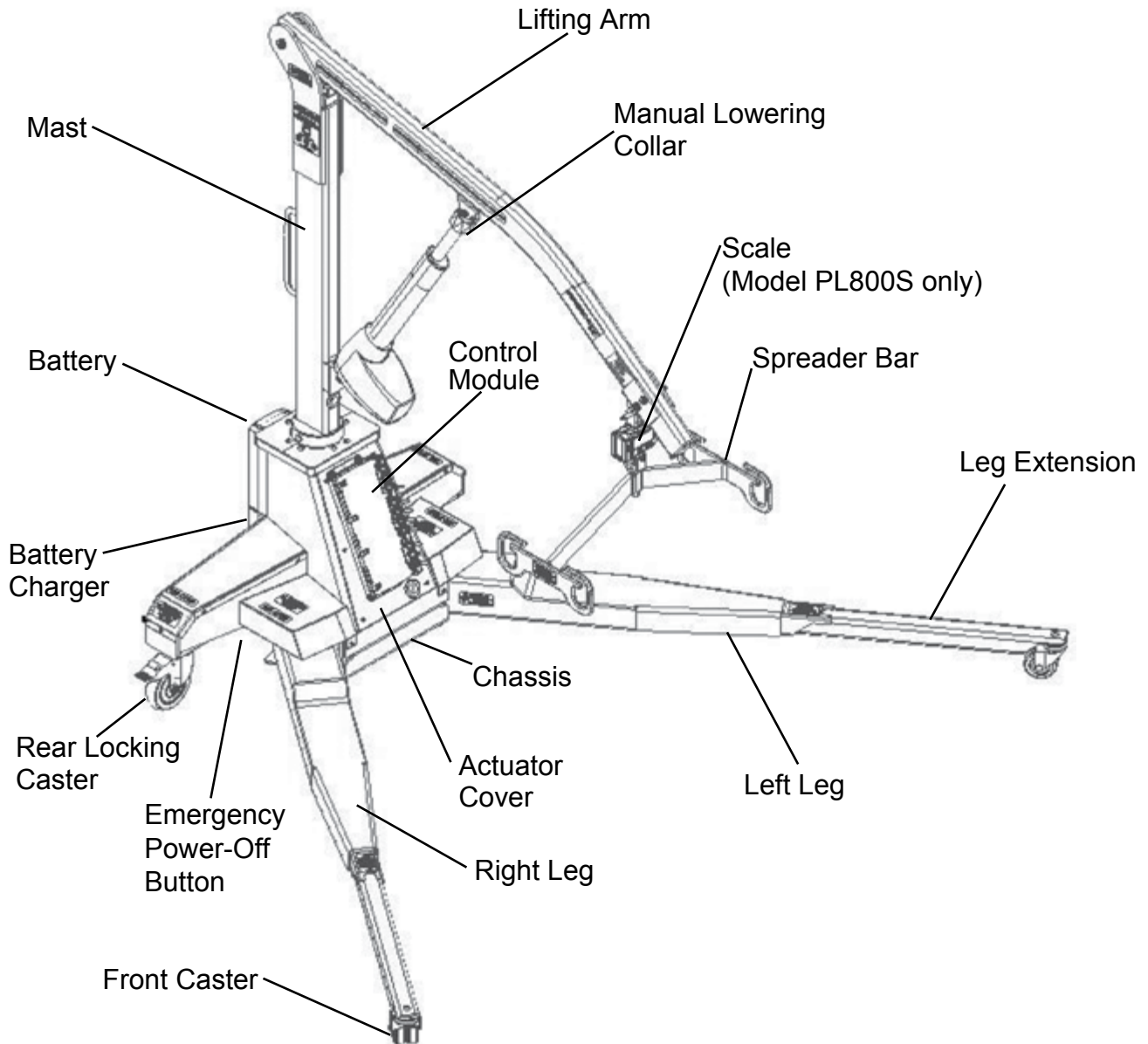

▲ **NOTICE:** The lift is inoperable while charging.

4 HANDLING PROCEDURES

SHIPPING AND TRANSPORTATION INSTRUCTIONS

If the patient lift is to be reshipped by common carrier, it should be packed in the same carton in which it was received.

Unpacking

⚠ WARNING: The lift is heavy. To avoid personal injury, DO NOT attempt to remove the lift from the box without assistance.

1. Check for any obvious damage to the carton or its contents. If damage is evident, notify the carrier or your GF authorized distributor.
2. Remove all loose packing from the carton.
3. Carefully remove all the components from the carton.

Info: Unless the patient lift is to be used immediately, retain boxes, containers and packing material for use in storing until use of patient lift is required.

Inspection

1. Examine the exterior of the patient lift for nicks, dents, scratches or other damage.
2. Inspect all components.

Storage

1. Store the repackaged patient lift in a dry area.
2. DO NOT place other objects on top of the repackaged patient lift.

▲ NOTICE: The lift is inoperable while charging.

5 SETUP

CHARGING THE BATTERY

To charge the lift battery, ensure the battery is installed on the lift and plug in the AC power cable.

▲ **NOTICE: The lift is inoperable while charging.**

▲ **NOTICE: Always recharge the battery after each use.**

Power requirement

Electrical hazard may occur if device is plugged into inadequate power supply. A power source of 90-240V AC & 50-60 Hertz must be available to charge the lift battery.

LIFT PREPARATION

In order to reduce the risk of the MaxiCare Patient Lift being put into an unstable use condition, certain electronic safety measures have been programmed into the lift control module. The following are the programmed safety conditions for operating the lift.

1. The mast rotation has a programmed stop point (Home Position) approximately centered between the legs. During any mast and lifting arm rotation, if the rotation comes to this point, the rotation will stop. During a patient transfer, the rotation button on the handset must be released and pressed again to continue the mast rotation.
2. For the leg functions to open / close and extend / retract, the mast rotation must be at Home Position and the lifting arm must be completely lowered. If either of these two conditions are not met, no leg function can occur.
3. For the lifting arm to raise / lower and the mast to rotate, the legs must be fully extended and completely open. If either of these two conditions are not met, no mast or lifting arm function can occur.

Perform the following checks before using the lift:

1. Do a careful walk around inspection of the lift. Look for any damage to the legs, mast, lifting arm, or spreader bar assembly.
2. Inspect the lift actuators. Ensure the bolts and nuts are tight. Check the actuators for any deep scratches or dents.
3. Lock the rear casters in place. The wheels should not turn and the casters should not rotate.
4. Check the battery level. If the battery is low, charge it.
5. Check the sling for the following items:
 - a) Inspect for any wear, discoloration, abrasions, holes, cuts or frays.
 - b) Inspect sling and straps for any broken, worn, pulled, or unraveled stitches.
 - c) Inspect sling for heat or bleach damage by noticing any color changes, brittle or puckered spots on the material.
 - d) Inspect the straps for any noticeable discoloration, fatigue, damage, or wear.

If problems are found, contact GF customer service at 1.770.368.4700.

Selecting the appropriate sling

To determine if a sling is of proper size, lay it across the patient's chest. When correct, you should find between two and eight inches of extra material extending past each arm. If little or no fabric extends beyond the patient's arms a larger sling is required.

Info: This is only a guide. Body shapes can vary greatly, so correct sling sizing should be determined by the health care professional.

There are positioning handles on the sides and backs of each Gendron sling. These handles are color-coded depending on size & style of the sling, which simplifies the task of identifying the correct sling for each individual patient.

Info: Positioning handles should always face outward, away from the patient.

List of Gendron slings

Gendron Hammock Slings		
Model	Handle Color	Weight Capacity
GT4XL	Green	400 lb — 800 lb / 181 kg — 362 kg
GT5XL	Orange	400 lb - 1,000 lb / 181 kg — 453 kg
GT5XLC*	Red	400 lb - 1,000 lb / 181 kg — 453 kg

* Model GT5XLC includes a commode opening

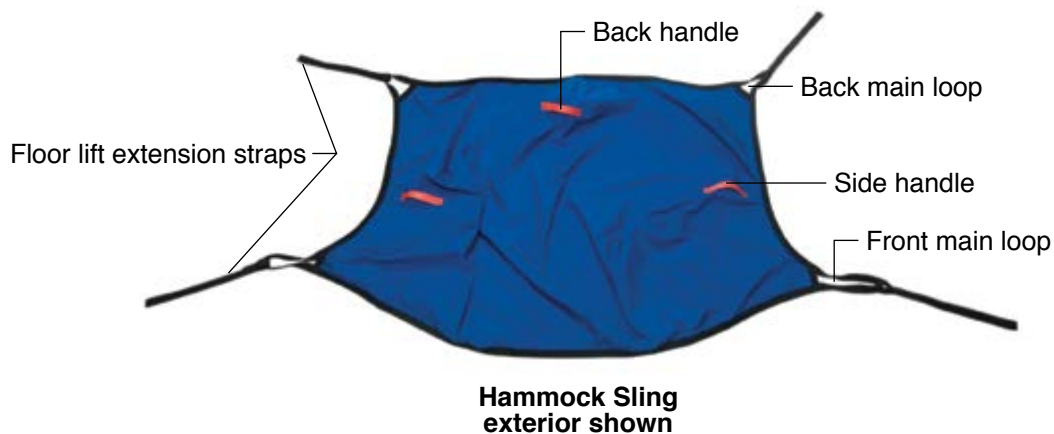

The Gendron hammock style sling, shown above, has four each permanently attached main lifting loops and floor lift extension straps, two each on each side. There are also three color coded attendant guide handles on the sling exterior. The front main lifting loops are longer than the back main lifting loops.

6 OPERATION

LIFT OPERATION – GENERAL WARNINGS

Info: Instructional videos that review the application of several sling styles and lifting scenarios are available at www.grahamfield.com.

- ⚠ WARNING: The patient lift legs must be in the maximum open and fully extended position in order for any lift or rotation functions to operate.**
- ⚠ WARNING: Use only Gendron slings specially designed for the Gendron PL800 Patient Lift.**
- ⚠ WARNING: Do not put anything (e.g. cushion, pad, etc.) between the user and the sling. This may cause user to slide out of the sling and could cause injury.**
- ⚠ WARNING: GF Health Products, Inc. strongly recommends that two caregivers take part in the lifting process.**
- ⚠ WARNING: Do not attempt to transfer a patient without prior approval of the patient's healthcare professional and without having read the instructions and practiced using the patient lift.**
- ⚠ WARNING: Use special care for those patients who cannot cooperate while being lifted.**
- ⚠ WARNING: Ensure all bolts, hooks, and loops are securely fastened.**
- ⚠ WARNING: Use only Gendron slings with the Gendron PL800 Patient Lift.**
- ⚠ WARNING: DO NOT use torn, cut, frayed or broken slings as injury could result.**
- ⚠ WARNING: Ensure the floor area is clear of any obstacle that could cause a caster to stop and possibly tip the patient lift.**

USING THE HANDSET

The MaxiCare Patient uses four 24V DC electric actuators to operate the lift.

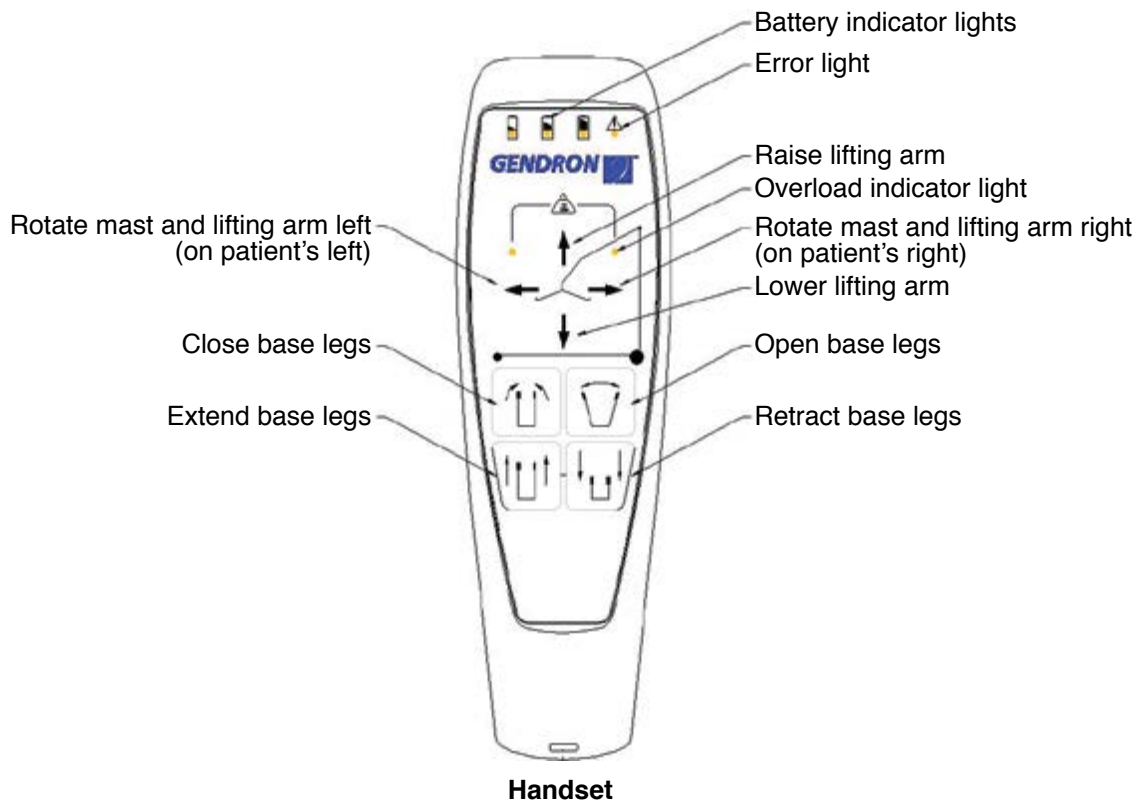

The eight-button, four-function handset, shown above, controls the four functions of lift positioning:

- Extend and retract the legs
- Open and close the legs
- Raise and lower the lifting arm
- Rotate the mast and lifting arm left and right

LOCKING THE CASTERS

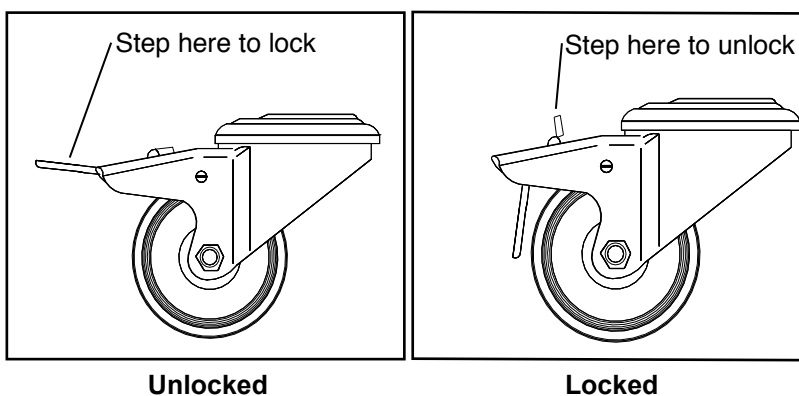

The locking function holds the lift motionless. Lock the rear casters when transferring the patient. For stability when rotating the mast, the mast is centered between the legs and the casters should be positioned parallel to the mast.

POSITIONING THE LEGS

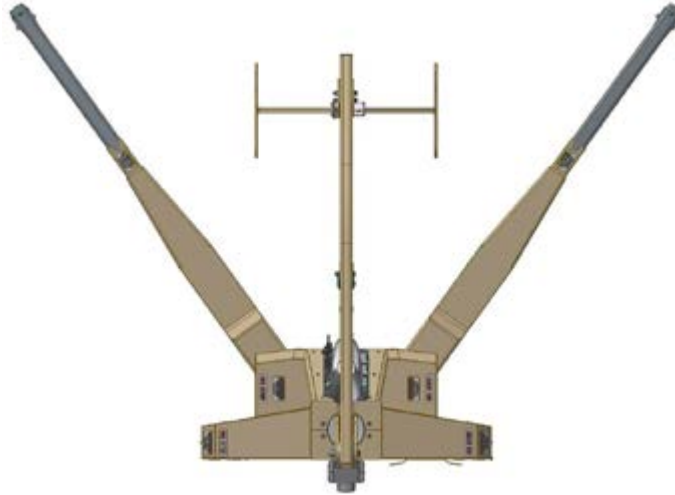

The lift legs must be fully extended and completely opened before elevating the lifting arm or rotating the mast. The electronic safety feature will not allow the lifting arm to elevate or the mast to rotate unless the legs are fully extended and completely open.

LIFTING THE PATIENT

Ideal and alternate lifting position to or from bed

Info: Note ideal MaxiCare Lift positions are shown below:

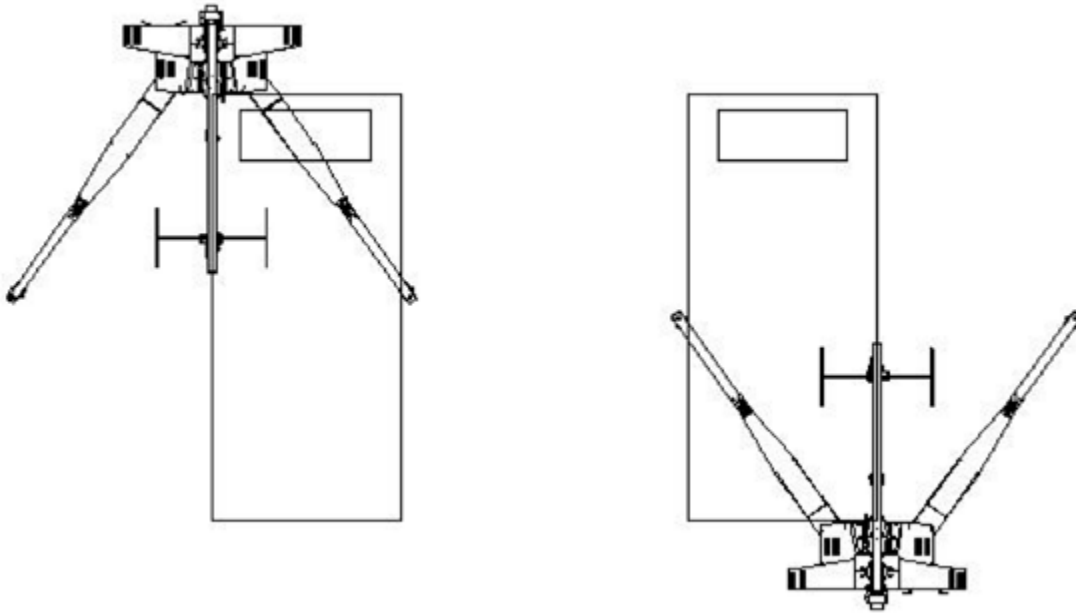

Info: Note alternate MaxiCare Lift positions are shown below:

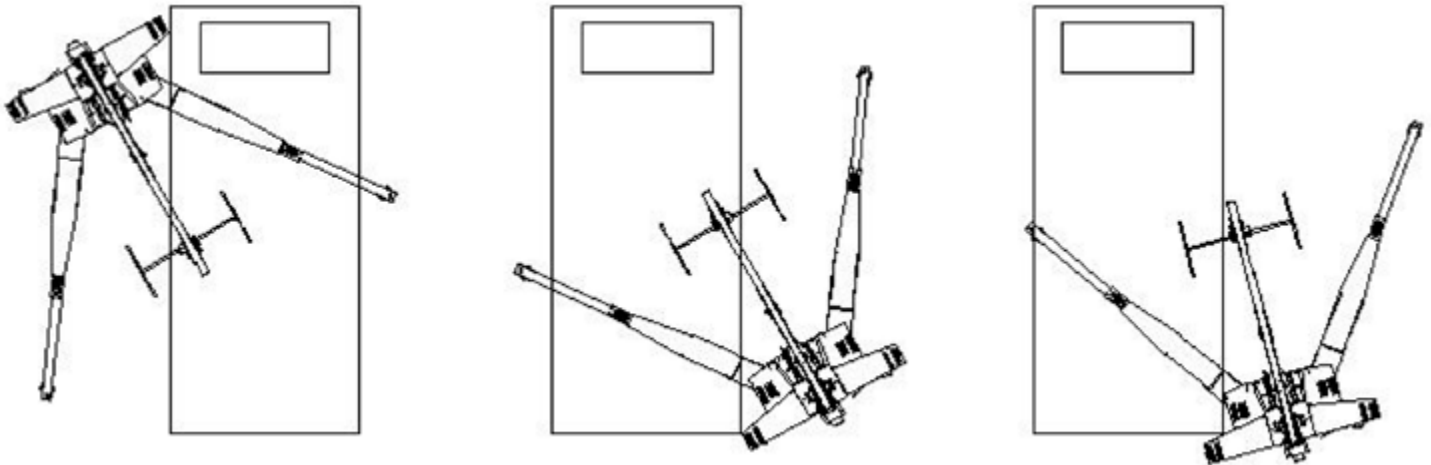

Positioning the legs

Lifting the patient from a bed or floor with a full-body sling

1. Position patient face-up in center of bed (or floor). Roll patient onto their side facing away from you.
2. Fold sling lengthwise, face down, and place it halfway under patient with lower edge just beneath knees and sling handle on the outside, facing away from patient. If the sling has a head support, ensure that it supports the patient's neck and head.
3. Roll patient onto their side facing you. Pull sling out beneath patient inside up, smooth it, and center patient on sling.
4. Roll the patient lift under the bed (or around the patient's head if on the floor), locating the spreader bar over the patient. Be careful not to lower the spreader bar onto the patient. Center the spreader bar over the patient before lifting.

⚠ WARNING: The rear casters must be locked to prevent movement while the patient is lifted.

⚠ WARNING: The patient lift legs must be in the maximum open and fully extended position in order for any lift or rotation functions to operate.

5. Hook the sling loops onto the spreader bar, head loops followed by leg loops.

⚠ WARNING: Ensure that the loops are completely settled into the bottom of the side plates of the spreader bar, as shown at right.

6. If the patient is in an adjustable bed, raise the bed's head section to elevate the patient.
7. Carefully and slowly raise the patient. If possible, lower the bed. Reposition the patient as needed, using the handle on the back of the sling, to ensure a safe and comfortable sitting position as the patient is raised.
8. Raise the patient until the buttocks are just above the mattress (or off the floor). Lift the patient's legs and turn the patient to face the lifting column. Move the patient lift away from the bed. Ensure that the patient's arms and legs clear the patient lift, bed, or any other obstacles.



Lowering the patient onto a bed

1. Raise the patient lift until the patient's buttocks are above the surface of the bed. Ensure that there are no obstacles underneath or around the bed. Move the patient lift under the bed. Ensure the patient does not hit any portion of the bed and that the patient's legs have cleared the bed.
2. Center the patient over the bed, and rotate the patient to face the foot section of the bed. SLOWLY lower the patient onto the bed. Support the patient's head, if necessary, while being lowered. Remove the sling by reversing the procedures used when lifting patient from bed.

Transferring the patient from a chair to a wheelchair or commode chair with a universal sling

⚠ WARNING: GF Health Products, Inc. recommends that two attendants be used when transferring a patient to and from a wheelchair.

1. While maintaining support, gently lean the patient forward. Place the sling behind the patient's back and push it down until it touches the seat of the chair.
2. Use the straps to pull the leg sections of the sling forward and beneath the patient's thighs. Then cross the straps, one through the other.
3. Move the patient lift around to the front of the chair.
4. Hook all sling loops onto the spreader bar: first head straps, followed by middle straps, then leg straps.
5. Carefully raise the patient.
6. The second attendant should now move the wheelchair into position.
7. Engage the wheelchair wheel locks to prevent movement.

⚠ WARNING: Before transfer, ensure wheelchair wheel locks are in locked position. Wheelchair wheel locks must be in LOCKED POSITION before lowering the patient into the wheelchair, or unexpected wheelchair movement could result, which may result in serious injury to both the patient and the attendants.

8. Position the patient over the wheelchair with their back against the back of the wheelchair.
9. SLOWLY lower the patient into the wheelchair.
10. With one attendant behind the wheelchair and the other operating the lift, the attendant behind the chair should pull back on the handle or sides of the sling to place the patient into the back of the chair. This will maintain a good center of balance and prevent the chair from tipping forward.

Removing the sling

Gently pull the leg sections to the side, out from under the patient's thighs. Standing by the patient's side, lean the patient forward while supporting the patient with one hand. Pull the sling up from behind the patient's back and position the patient in the chair.

⚠ WARNING: DO NOT pull sharply on the sling. Pulling sharply on the sling may cause the patient to fall forward, resulting in personal injury. Always support the patient by keeping one arm around the patient's shoulders when placing or removing the sling.

Info: If possible, the patient should be encouraged to take an active part in removing the sling. The patient can lean forward, lift their thighs, and help in removing the leg sections.

Transferring the patient from a bed or floor to a wheelchair or commode chair with a full-body sling

1. For smooth, easy lifting, have the wheelchair or commode chair in ready position with wheel locks in locked position.
 2. Position patient face-up in center of bed (or floor). Roll patient onto their side facing away from you.
 3. Fold sling lengthwise, face down, and place it halfway under patient with lower edge just beneath knees and sling handle on the outside, facing away from patient. If the sling has a head support, ensure that it supports the patient's neck and head.
 4. Roll patient onto their side facing you. Pull sling out beneath patient inside up, smooth it, and center patient on sling.
 5. Roll the patient lift under the bed (or around the patient's head if on the floor), locating the spreader bar over the patient. Be careful not to lower the spreader bar onto the patient. Center the spreader bar over the patient before lifting.
- ⚠ WARNING: The rear casters must be locked to prevent movement while the patient is lifted.**
- ⚠ WARNING: The patient lift legs must be in the maximum open and fully extended position in order for any lift or rotation functions to operate.**
6. **Hook the sling loops onto the spreader bar, head loops followed by leg loops.**
 7. If the patient is in an adjustable bed, raise the bed's head section to elevate the patient.
 8. Carefully and slowly raise the patient. If possible, lower the bed. Reposition the patient as needed, using the handle on the back of the sling, to ensure a safe and comfortable sitting position as the patient is raised.
 9. Raise the patient until the buttocks are just above the mattress (or off the floor). Lift the patient's legs and turn the patient to face the lifting column. Move the patient lift away from the bed. Ensure that the patient's arms and legs clear the patient lift, bed, or any other obstacles.
 10. Position patient above wheelchair or commode chair. Lock lift brakes.
- ⚠ WARNING: Before transfer, ensure wheelchair or commode chair wheel locks are in locked position. Wheelchair wheel locks must be in LOCKED POSITION before lowering the patient into the wheelchair, or unexpected wheelchair movement could result, which may result in serious injury to both the patient and the attendants.**
11. SLOWLY lower patient. During descent, assist patient in attaining correct sitting posture.
 12. When patient is seated, push down on boom to slacken sling loops. Patient can remain seated on sling.
 13. For commode chair use (use full body sling with commode opening), adjust clothing before moving lift to straddle commode chair. Keep sling loops taut and ensure that patient is in a comfortable position.

EMERGENCY POWER-OFF BUTTON AND LOWERING COLLAR



Red Emergency Power-Off Button



Lowering Collar

If problems are encountered during use of the Patient Lift, power can be immediately stopped by pressing the red Emergency Power-Off Button located at the bottom center base back, shown at above left. The Emergency Lowering Collar is located at the top of the actuator shaft, as shown at above right. It is intended for use if the actuator fails to operate while a patient is suspended. The device consists of a plastic collar ring that should be turned in the direction shown by the arrows on the collar continually until the patient has been lowered.

Contact your dealer immediately if standard troubleshooting techniques do not correct the failure. Do not attempt to lift patients until all failure issues have been safely resolved.

Info: The emergency Power-Off Button and Lowering Collar are intended for use during lift failure. This device will allow lowering of patients only. Contact GF Tech Support at 1.770.368.4700 or your GF authorized distributor immediately in case of lift failure.

Contact your dealer immediately if standard troubleshooting techniques do not correct the failure. Do not attempt to lift patients until all failure issues have been safely resolved.

PL800S ONLY: OPERATING THE SCALE AND WEIGHING THE PATIENT

Scale illustration / component identification

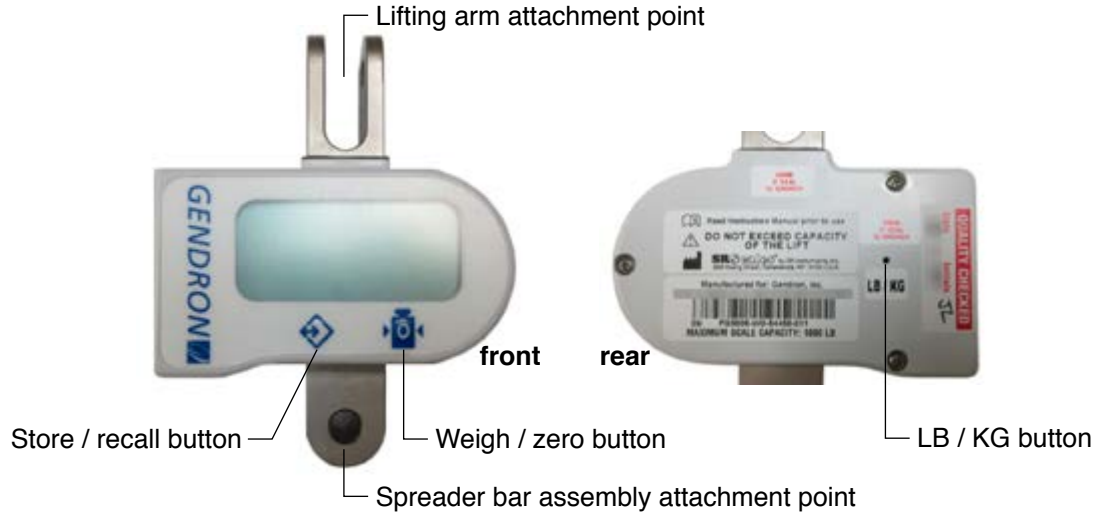

Scale

Scale component identification

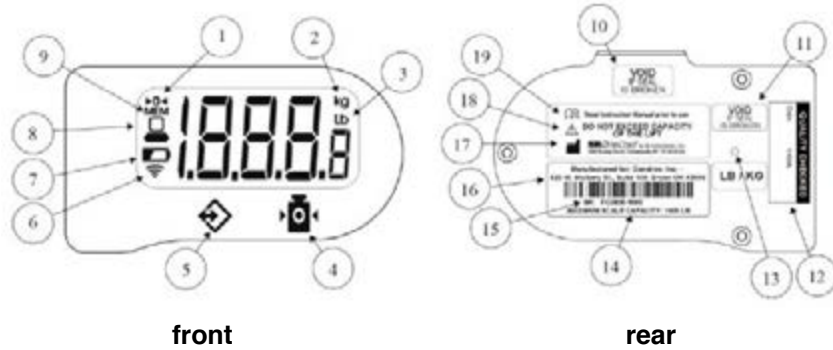

Item	Component
1	Zero Indicator
2	Kilogram Indicator
3	Pound Indicator
4	Weigh / Zero Button
5	Store / Recall Button
6	Not applicable for this model
7	Low Battery Indicator
8	Stable weight indicator
9	MEMORY indicator

10	Seal - DO NOT REMOVE
12	Calibration seal
12	Quality check
13	Access for Pound / Kilogram Mode button
14	Maximum scale capacity
15	Model - Serial Number
16	OEM address
17	Manufacturer address
18	DO NOT exceed lift capacity
19	Read instructions for use before operation





Preparation for weighing the patient

1. Ensure all hardware is tight and secure.
2. Zero out the weight with the sling and spreader bar before taking the patient weight measurement. Make sure it is not included in the patient weight measurement.
3. Never zero out the scale with the patient suspended. This will provide a false reading.
4. Make sure the sling is the only thing supporting the patient and that motion has minimized before taking a weight measurement.
5. If the scale turns off before you are ready, press the WEIGH button to turn it back on.

Weighing the patient

1. Press the WEIGH / ZERO button (right button) on the front of the display (shown at above left) to turn on the scale.
2. Use a pin to press the LB / KG button on the back of the scale (shown at above right) to select between lb (pounds) or kg (kilograms) for measurement unit.
3. Hang the sling from the spreader bar and press the ZERO button (right button) on the front of the display to zero out the scale. “0” will scroll across the display for a few seconds, then “0.0” will display.
4. Remove the sling from the spreader bar and position it under patient. Once the sling is reattached to the spreader bar and the patient is lifted free of any obstructions, press the POWER/WEIGH button to display the weight. The readout will increase slowly until it reaches the patient’s weight. The weight will display for approximately 60 seconds.

Scale Error Messages

Error Display	Symptom	Reason
	Battery will display for approximately ten seconds after startup	Battery charge is low; charge or replace battery
	Battery without display	Battery charge is critically low; system will not function until battery is charged or replaced
	Over-range display	Excessive load on scale or internal connection damage
	Low data input to electronics	Broken internal electrical connection

7 CARE AND MAINTENANCE

Proper care and maintenance are essential to keeping your Gendron PL800 Patient Lift in a safe operating condition. In addition to inspecting the unit before each use, periodic maintenance checks should be done.

- ⚠ WARNING: It is extremely important that the patient lift be inspected before each use. Ensure that all hardware and accessories are secure and that the actuator is functioning properly. Failure to do so could result in patient / attendant injury or damage to your patient lift. Torn, cut, frayed or broken slings can fail, resulting in serious injury. Only use slings in good condition. Inspect before each use. Destroy and discard old worn and unusable slings.**
- ⚠ WARNING: Service and repair of the Gendron PL800 Patient Lift MUST be performed by qualified personnel ONLY.**
- ⚠ WARNING: Unauthorized modification of the patient lift or the use of non-Gendron replacement parts may change the structure of the lift and could create a hazardous condition, which may result in serious injury and will void the warranty.**
- ⚠ WARNING: The electronics and actuator contain no serviceable components. DO NOT attempt to open the electronics or actuator. If service is required, consult GF Tech Support at 1.770.368.4700 for further information.**

When you believe a component or part is not functioning properly, immediately contact GF Tech Support at 1.770.368.4700, as a potentially hazardous condition could exist.

BEFORE EACH USE

Before each use of the patient lift, ensure that:

- All nuts and bolts are tight
- The base can be easily widened
- All lift parts are in place
- All casters turn freely
- Caster brakes can be engaged
- All necessary items (i.e. slings, wheelchairs, etc.) are accessible and ready for use
- Check battery capacity

AT LEAST ONCE A MONTH

The lift should be thoroughly inspected by a person qualified to recognize any signs of wear, and looseness of bolts or parts. Replace any worn parts immediately.

LUBRICATION

When the lift is serviced, and every month thereafter, place a drop of lubricant (White Lithium Grease is recommended) on the following points:

- Top of mast
- Spreader hinge
- Caster axles

CLEANING

Regular cleaning is recommended every three months; clean the lift more often as needed. A soft cloth, dampened with water and a mild NON-ABRASIVE detergent (household cleaner, soapy water, or hospital grade disinfectant) is all that is needed to clean your patient lift. Automobile wax or furniture polish will help maintain the finish over a long period of time.

▲ **NOTICE: DO NOT pressure wash or steam clean lift.**

CARE OF SLINGS

Gendron slings are washable at 120°F / 48°C or less. If there is a removable plastic insert in the head support, remove insert before washing. Air dry or dry at temperature less than 120°F / 48°C.

▲ **NOTICE: DO NOT bleach slings!**

MAINTENANCE SCHEDULE

Info: Only qualified persons should service and repair your Gendron PL800 Patient Lift. Regular maintenance of your patient lift is necessary to ensure continuing proper and safe operation. Read and observe the following recommended maintenance schedule:

Item	Inspect	Inspect / Adjust	
	initially	monthly	every 3 months
Lifting arm and spreader bar			
Check connections between 1) boom and spreader bar and 2) boom and mast for improper connection, looseness, or wear	X	X	
Inspect boom for bending or deflection	X	X	
Mast			
Inspect mast for bending or deflection	X	X	
Inspect steering bar for damage or loose hardware	X	X	
Base			
Ensure all hardware is tight	X	X	
Ensure casters and axle bolts are tight	X	X	
Inspect rubber parts of casters for deflection	X		X
Apply grease to caster ball bearings if needed			X
Actuator and control box			
Ensure control box is firmly affixed to the base front cover	X	X	
Ensure pins that connect actuator to boom and mast are firmly affixed	X	X	
Ensure cables that connect actuators and control box are firmly affixed	X	X	
Ensure battery indicator has at least 2 green LEDs illuminated before use	X	X	
Sling and sling hardware			
Check sling for wear; discard if worn	X	X	
Ensure sling hardware is in good condition before each use	X	X	

8 TROUBLESHOOTING

The following list of encountered problems and their solutions will assist you in determining what may be causing your Gendron lift not to function as designed. If you have a problem occurring which is not listed below, contact GF Tech Support at 1.770.368.4700 for further information. Do not attempt to repair components or parts on your lift, as this may invalidate your warranty or cause further problems that may result in patient injury. Stop using your lift immediately if it is not functioning correctly or any warning beeps are heard.

If any of the following notifications, follow the steps below to troubleshoot:

TROUBLESHOOTING GUIDE		
Problem	Cause	Solution
No power to the lift	Battery is in Standby Mode	Connect the AC power for at least 15 seconds (see Battery Technical Guide below)
	Dead Battery	Charge or replace Battery
	Emergency Power-Off Tripped	Reset the Emergency Power-Off Button
	Cable between power supply and control module disconnected	Re-connect cable
No functions working on lift but power present	One of the safety conditions has not been met	Ensure the lifting arm is completely lowered and the mast is in Home Position Ensure the legs are completely extended and fully open
	AC power cable is plugged in	Unplug AC power cable
	Battery is in Deep Discharge Protection	See following Battery Technical Guide
Battery will not charge when lift is plugged in	Bad Battery	Replace Battery
	Charger Failure	Replace Battery Charger
	Safety Limit Switch not activated	Lower the lifting arm to activate the switch
Leg Extending and/or Opening Actuators do not move	Mast not in Home Position	Rotate mast to Home Position stop point between the legs
	Cable disconnected	Re-connect cable
	Legs not fully extended and open	Fully extend and fully open the legs
Lifting Arm and/or Mast Pivot Actuators do not move	Cable disconnected	Re-connect cable

⚠ WARNING: If you experience a problem with your lift and are unable to service it yourself, contact GF Tech Support at 1.770.368.4700 or your GF authorized distributor.

BATTERY TECHNICAL GUIDE

Standby mode

When the battery is not used for a long period of time (more than a week), it enters standby mode to save power and protect the battery from deep discharge.

- Connect the charger for approximately fifteen seconds to exit standby mode before use.
- There is no audio signal to indicate standby mode or exit of standby mode.

After exiting standby mode

- If there is still no power, the battery needs to be charged.
- After charging, the handset and / or control box will re-indicate the battery capacity level.

Deep discharge protection

The battery has deep discharge protection to extend the battery lifetime. Deep discharge protection is activated when the battery is discharged.

- Connect the charger for approximately fifteen seconds to exit deep discharge mode before use.

If the battery is completely discharged, the charging will start at a very low rate to protect the battery. This low charging rate is not sufficient to illuminate the charger light, and therefore, the user may believe that the system has not yet started charging. Depending on the battery state, it may take several hours to reach a normal charging state. The control box orange light will not illuminate, since the operation is analog; it is therefore not possible to see that the charging has started, however, only a low level.

9 SPECIFICATIONS

Info: All dimensions are given in inches unless otherwise specified.

Environmental conditions	Operation	Temperature	41°F to 86°F / 5°C to 30°C
		Relative humidity	20% to 90% @ 86°F / 30°C non-condensing
		Atmospheric pressure	700 hPa to 1060 hPa
	Storage and Transport	Temperature	14°F to 104°F / -10°C to 40°C
		Relative humidity	20% to 90% @ 86°F / 30°C non-condensing
		Atmospheric	700 hPa to 1060 hPa
Maximum external base width	Legs open	85" / 215.9 cm	
Base height clearance	4.75" / 12 cm		
Overall base length	61.69" / 156.7 cm		
Base angle between legs	72° Maximum with legs completely open		
Mast rotation angle	60° Maximum		
Lifting height range, measured from floor to clevis at leg end of lifting arm	Minimum	43.31" / 110 cm	
	Maximum	78.56" / 199.5 cm	
	Range: 35.25" / 89.5 cm		
Maximum weight capacity	800 lb / 362 kg, EVENLY DISTRIBUTED		
Caster size	Legs	Two heavy-duty 5" diameter locking	
	Rear	Two double-wheel 3" diameter swivel	
Lifting mechanism	24V DC actuator		
Power supply	24V DC Lithium-Ion Battery		
Power cable plug	Two-prong plug for battery charging		
Duty cycle	10% maximum, or 2 min. continuous use followed by 18 min. not in use		
Classification	Class 1, Internally Powered		

10 LIMITED WARRANTY

SCOPE OF WARRANTY

GF Health Products, Inc. (“GF”) warrants to the original purchaser only that it will replace or repair components, at GF’s sole discretion, that are defective in material or workmanship under normal use and service. All warranties are conditioned upon the proper use of the products strictly in accordance with good commercial practice and applicable GF instructions and manuals, including proper use and maintenance. To the extent that a component is warranted by a third party, GF conveys all of its rights under that warranty to the original purchaser, to the extent permitted. This limited warranty shall only apply to defects that are reported to GF’s customer service team within the applicable warranty period and which, upon examination by GF or its authorized representative, prove to be a warranty item. This limited warranty is not transferable.

The warranted components and time period are set forth below:

Lift frame and spreader bar:..... five years
Actuators, bearings, casters, control module, handset, and pins:..... one year

The applicable warranty period shall commence from date of shipment to the original customer, unless there is an expiration date on the component in which case the warranty shall expire on the earlier of warranty period or the expiration date.

OBTAINING WARRANTY SERVICE

This limited warranty shall only apply to defects that are reported to the Distributor from whom the Customer purchased the product within the applicable warranty period. If there is not a Distributor, you must contact GF directly by calling 1.770.368.4700, sending a fax request to 1.770.368.2386, or by e-mailing a request to cs@grahamfield.com. Specific directions will be provided by the Customer Service Representative. Failure to abide by the specific directions will result in denial of the warranty claim.

The warranty does not cover and GF shall not be liable for the following:

- 1) Defects, damage, or other conditions caused, in whole or in part, by misuse, abuse, negligence, alteration, accident, freight damage, tampering or failure to seek and obtain repair or replacement in a timely manner;
- 2) Products which are not installed, used, or properly cleaned and maintained as required in the official manual for the applicable product;
- 3) Products considered to be of a non-durable nature including, but not limited to: filters, fuses, gaskets, lubricants, and charts;
- 4) Accessories or parts not provided by GF;
- 5) Charges by anyone for adjustments, repairs, replacement parts, installation or other work performed upon or in connection with such products which are not expressly authorized in writing, in advance, by GF;
- 6) Any labor or shipping charges incurred in the replacement part installation or repair;
- 7) Costs and expenses of regular maintenance and cleaning; and
- 8) Representations and warranties made by any person or entity other than GF.

ENTIRE WARRANTY, EXCLUSIVE REMEDY AND CONSEQUENTIAL DAMAGES DISCLAIMER

THIS WARRANTY IS GF'S ONLY WARRANTY AND IS IN LIEU OF ALL OTHER WARRANTIES, EXPRESS OR IMPLIED. GF MAKES NO IMPLIED WARRANTIES OF ANY KIND INCLUDING ANY IMPLIED WARRANTIES OF MERCHANTABILITY OR FITNESS FOR A PARTICULAR PURPOSE. IF ANY MODEL OR SAMPLE WAS SHOWN TO THE CUSTOMER, SUCH MODEL OR SAMPLE WAS USED MERELY TO ILLUSTRATE THE GENERAL TYPE AND QUALITY OF THE PRODUCT AND NOT TO REPRESENT THAT THE PRODUCT WOULD NECESSARILY CONFORM TO THE MODEL OR SAMPLE IN ALL RESPECTS. THIS WARRANTY IS LIMITED TO THE REPAIR OR REPLACEMENT OF THE DEFECTIVE PARTS. GF SHALL NOT BE LIABLE FOR AND HEREBY DISCLAIMS ANY DIRECT, SPECIAL, INDIRECT, INCIDENTAL, EXEMPLARY OR CONSEQUENTIAL DAMAGES, INCLUDING, BUT NOT LIMITED TO: DAMAGES FOR LOSS OF PROFITS OR INCOME, LOSS OF USE, DOWNTIME, COVER, OR EMPLOYEE OR INDEPENDENT CONTRACTOR WAGES, PAYMENTS AND BENEFITS.

The warranties contained herein contain all the representations and warranties with respect to the subject matter of this document, and supersede all prior negotiations, agreements and understandings with respect thereto. The recipient of this document hereby acknowledges and represents that it has not relied on any representation, assertion, guarantee, warranty, collateral contract or other assurance, except those set out in this document.

For additional information on this product or this warranty, please contact a GF Customer Service Representative.

NOTES:

- 1) Additional terms and conditions may apply.
- 2) Freight claims must be notated on the appropriate shipping documents and must be made with immediacy. International, federal and state regulations govern specific requirements for freight claims. Failure to abide by those regulations may result in a denial of the freight claim. GF will assist you in filing the freight claim.
- 3) Claims for any short shipment must be made within three (3) days of the invoice date.

11 INDEX

A

Assembly instructions 8

B

Battery technical guide 22

Before each use 20

C

Care and maintenance 20

Care of slings 21

Casters, locking 11

CAUTION statement, significance 4

Charging the battery 8

Cleaning 21

D

Deep discharge protection 23

E

Electromagnetic compatibility (EMC) 5

Emergency power-off button and lowering collar 17

F

Features 6

G

Gendron slings, list 9

H

Handling Procedures 7

Handset, using 11

I

Ideal and alternate lifting position to or from bed 13

Info statement, significance 4

Inspection 7

Intended use 3

Introduction 3

L

Lifting the patient 13

Lifting the patient from a bed or floor with a full-body sling 14

Lift operation — general warnings 10

Lowering the patient onto a bed 14

Lubrication 20

M

Maintenance schedule 21

N

NOTICE statement, significance 4

O

Operation 10

P

PL800 only: scale illustration / component identification 18

PL800S only: operating the scale and weighing the patient 18

Positioning the legs 12

Preparation for weighing the patient 19

R

Radio Frequency (RF) communications equipment 5

Removing the sling 15

S

Safety precautions 4

Safety statements, significance of 4

Scale error messages 19

Selecting the appropriate sling 9

Shipping and transportation instructions 7

Specifications 24

Storage 7

T

Transferring the patient from a bed or floor to a wheelchair or commode chair with a full-body sling 16

Transferring the patient from a chair to a wheelchair or commode chair with a universal sling 15

Troubleshooting 22

U

Unpacking 7

V

Videos, instructional, at www.grahamfield.com 10

W

Warnings 4

WARNING statement, significance 4

Warranty, limited 25

Weight capacity, maximum 4



1.770.368.4700

Information contained herein is subject to change.
The most current and complete product information can be found on our website.
grahamfield.com / gendroninc.com

Follow us on  

© 2020, GF Health Products, Inc. All Rights Reserved.
Gendron is a trademark of GF Health Products, Inc.,
One Graham-Field Way, Atlanta GA 30340-3140

GF Health Products, Inc. is an ISO 13485:2016 / MDSAP Certified Company.

Manufactured by GF Health Products, Inc.
Made in USA